



AGTOS®

Overhead Rail Shot Blast Machines and Continuous Overhead Rail Shot Blast Machines

- Blast machines
- Pre-owned machines
- Conveyor systems
- Service and spare parts



Overhead rail shot blast machines come in many versions, types and sizes. They have a relatively small footprint. They are widely used because they are easy to integrate into a company's logistics.

Advantages of AGTOS overhead rail shot blast machines:

- Reliable blasting technology
- Low maintenance
- Innovative filter technology
- Robust construction

Important Advantages of AGTOS Overhead Rail Shot Blast Machines



→ AGTOS blasting technology

Our high performance turbine units are very reliable. They are highly efficient due to the low number of wearing parts, maintenance-friendly design and high abrasive flow rate.



→ Low maintenance

Regular maintenance helps maintain the value of the machines. Large maintenance doors provide easy access to all essential components and facilitate the rapid replacement of wearing parts.



→ AGTOS filter technology

The innovative filter technology has a convincing and powerful performance. The special characteristics include the conical filter cartridges which can be replaced quickly and easily via drawer elements outside the casing. These cartridge filter systems can also be retrofitted to older shot blast machines of most makes.



→ Robust construction

The sturdy construction uses special wear resistant steel with additional linings in areas subject to high wear. All helping to protect the owner's investment.

Fig. front page: Structural components exiting the manual re-blasting chamber of a continuous overhead rail shot blast machine

Components of an *AGTOS* Overhead Rail Shot Blast Machine

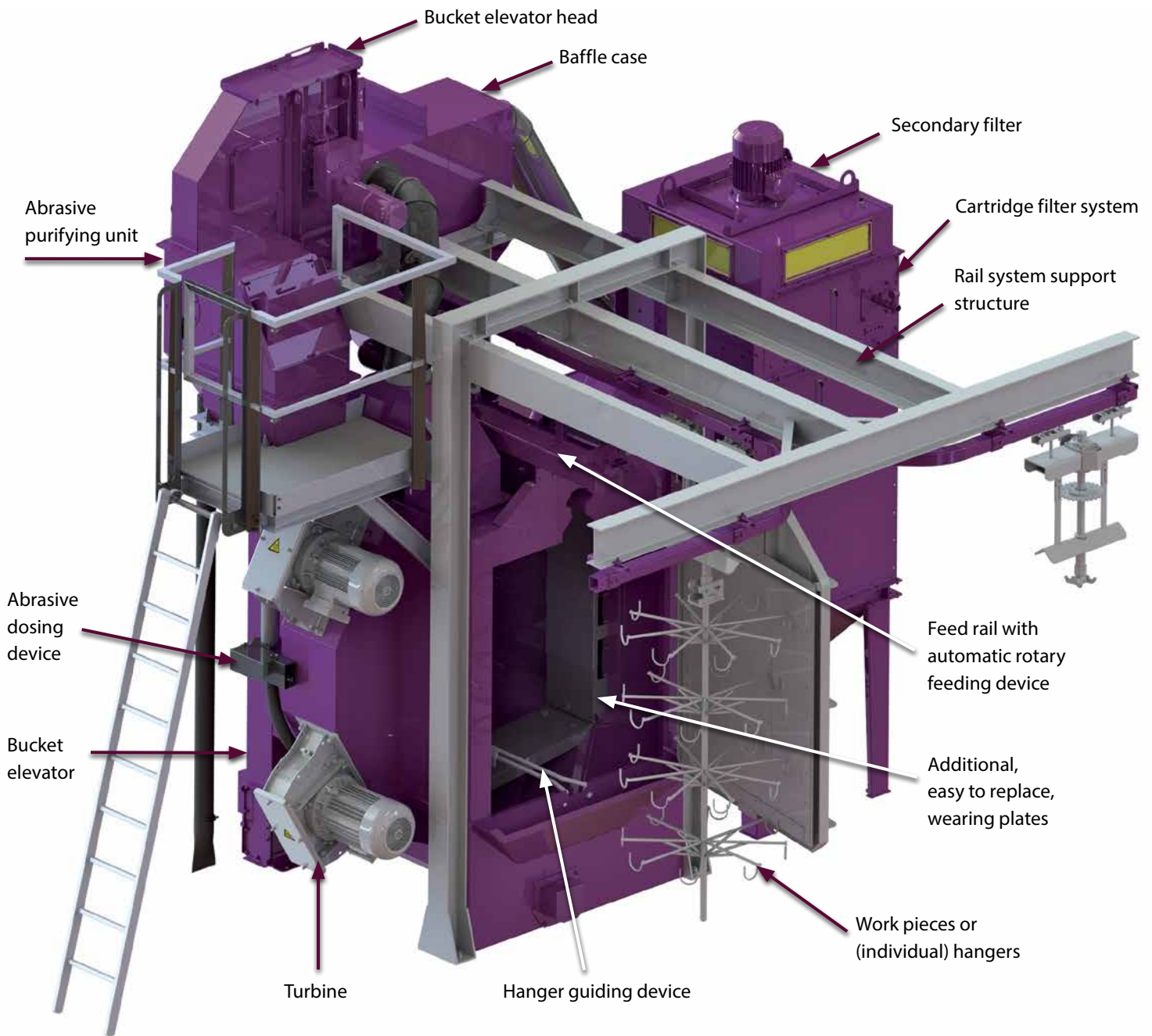

The abrasive is purified and circulated in the optimal process mixture.



Abrasive refill hopper on the bucket elevator (optional)



Robust overhead rail systems for any requirement

Integration With the Operational Process

Overhead rail shot blast machines can be used as isolated applications or integrated with the existing logistics. Many different options are available. Below are examples of the most common versions. Hangers and work pieces are fed into the machine automatically as soon as they reach it. Transport to the edge of the machine can be done either manually or with a conveyor system.

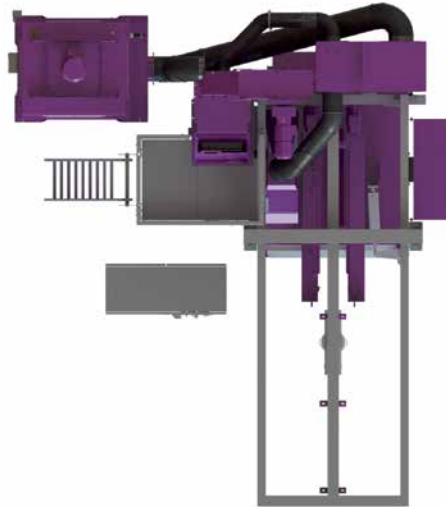

Operation of an overhead rail shot blast machine with monorail as an isolated application or in combination with a conveyor system.

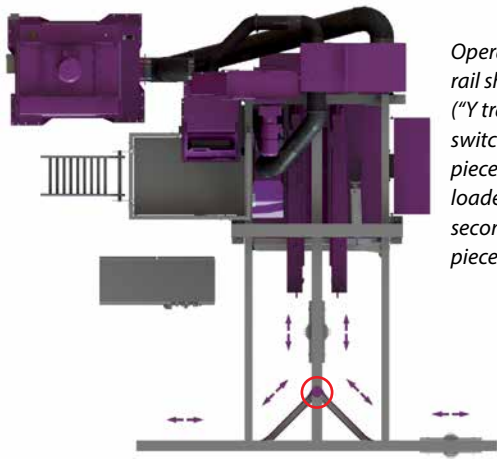

Operation of an overhead rail shot blast machine ("Y track") with one track switch. While one work piece hanger is being loaded or unloaded a second hanger or work piece can be blasted.

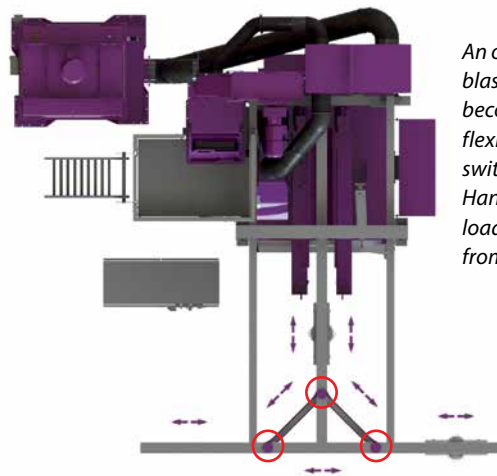

An overhead rail shot blast machine ("Y track") becomes even more flexible when three track switches are used. Hangers can always be loaded and unloaded from the same side.

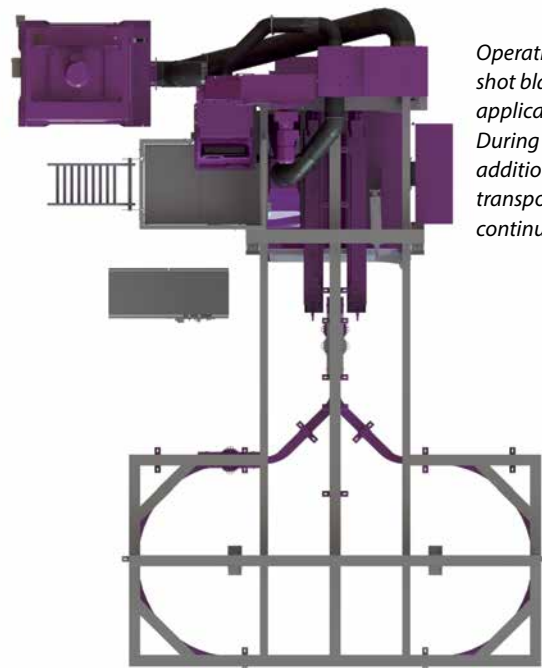

Operation of an overhead rail shot blast machine as an isolated application with an oval. During the blasting process additional hangers can be transported in or out to allow continuous processing.

Efficient Blasting with *AGTOS* Overhead Rail Shot Blast Machines – Installed Examples



Overhead rail shot blast machine for gear parts as an isolated application



Overhead rail shot blast machine for connecting components in a production line



Overhead rail shot blast machine with baseplate and blasting abrasive recirculation for the treatment of springs



Overhead rail shot blast machine in a foundry with magnetic separator and blasting abrasive recirculation upstream of the machine

Continuous Overhead Rail Shot Blast Machines

Continuous overhead rail shot blast machines are preferred whenever time is an important consideration. Work pieces are treated continuously. The continuous supply of work pieces reduces or eliminates non-productive times, such as time spent opening the door.



Continuous overhead rail shot blast machine for welded components with manual re-blasting and blowing chamber



Continuous overhead rail shot blast machine for welded components with turbines on one side



Continuous overhead rail shot blast machine for forged pieces with turbines on both sides



Continuous overhead rail shot blast machine for welded components with manual re-blasting and blowing chamber

Service for blasting machinery



Used machines are technically overhauled and then integrated with plant operations. Working on its own or as a general contractor, **AGTOS** undertakes disassembly, transport and re-assembly of the machines.



Modernization and increased performance of used machines through modern turbine technology among other features

We place special emphasis on providing first class customer service. This applies not only to the blasting equipment we manufacture, but also to other makes of equipment. Our service program includes:

- Wear and Spare Parts
- Repair and (remote) maintenance
- Inspection and process advice
- Machine upgrades and performance enhancement
- Upgraded used machines
- Orientation and Training



Turbine parts for many turbine brands



A wide range of abrasive types can be delivered at short notice.



In addition to replacement turbine parts, we also supply filter cartridges, cleaning and sealing brushes, and precut rubber and manganese blanks for many machine types.



Bucket elevator belts, buckets and screws for all makes of blast machinery

Modern blasting technology made-to-measure

AGTOS manufactures turbine hub blasting machines for custom mechanical engineering. Many different models of overhead rail shot blast machines are made to suit different types of work pieces as well as customers' requirements for surfaces and available space. The following table contains the most common models with their most important technical data.



Cast parts exiting the manual blowing chamber of a dual-chamber overhead rail shot blast machine



A steel girder after blasting in a continuous overhead rail shot blast machine

AGTOS overhead rail shot blast machines are available in different sizes, including the following standard sizes:

Technical Specifications	HT 11-13-2-11	HT 13-17-2-11	HT 13-21-3-11	HT 17-17-2-11	HT 17-23-3-11	HT 17-27-4-11	HT 21-23-3-11	HT 21-23-3-15
Max. hook load (kg)	400	400	400	800	800	800	800	800
Alternative max. hook load (kg)	800	800	800	1 600	1 600	1 600	1 600	1 600
Work piece diameter (mm)	1 100	1 300	1 300	1 700	1 700	1 700	2 100	2 100
Height of blasting zone (mm)	1 300	1 700	2 100	1 700	2 300	2 700	2 300	2 300
Turbine output (kW)	2x11	2x11	3x11	2x11	3x11	4x11	3x11	3x15
Cartridge filter	PF 4-09	PF 4-12	PF 4-12	PF 4-12	PF 4-12	PF 4-20	PF 4-20	PF 4-28
Suction output (m ³ /h)	2 600	4 500	4 500	4 500	4 500	7 500	7 500	10 000
Residual dust content with secondary filter (mg/m ³)	1	1	1	1	1	1	1	1

Additional equipment and hook loads are available.



AGTOS

Gesellschaft für technische
Oberflächensysteme mbH

Gutenbergstraße 14
D-48282 Emsdetten

Tel.: +49(0)2572 96026-0

info@agtos.de

www.agtos.com