

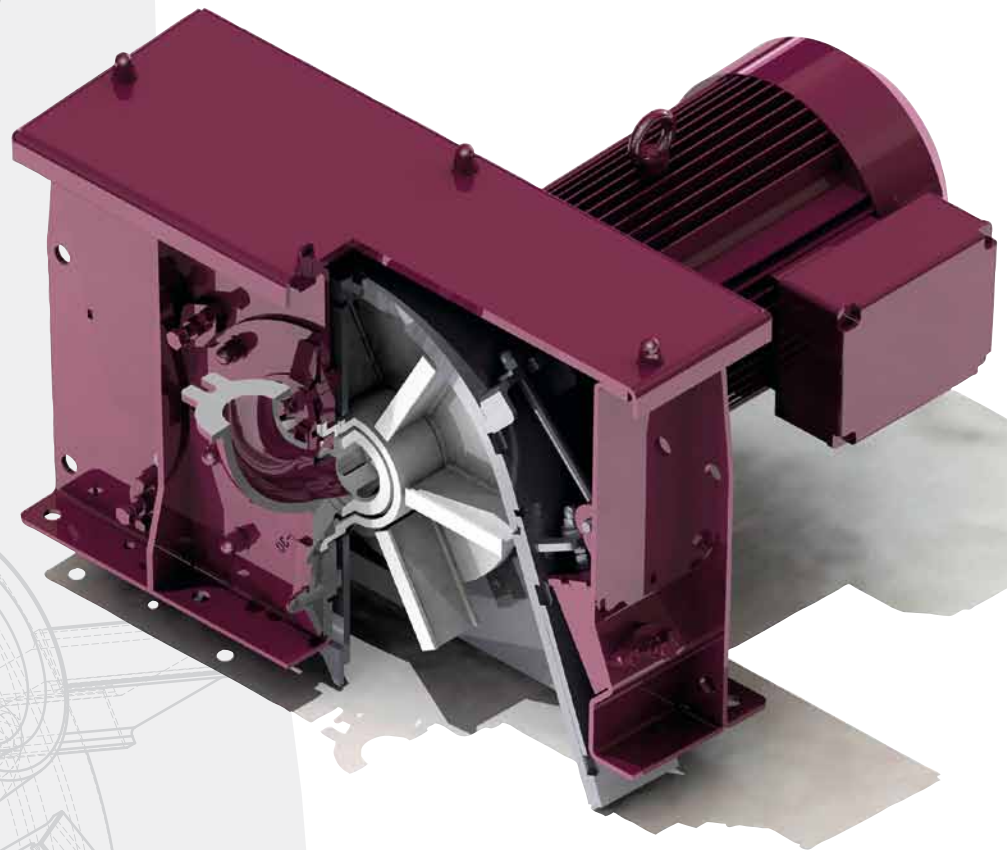

AGTOS[®]

AGTOS High Performance Turbines

- Blast machines
- Second-hand machines
- Conveyor systems
- Service and spare parts



Advantages of AGTOS High Performance Turbines:

- ➔ Rapid assembly,
no special tools required
- ➔ Less wear parts
- ➔ High performance due to high
abrasive throughput

Distinct Advantages of AGTOS High Performance Turbines

AGTOS high performance turbines have blasting wheels provided with six throwing blades locked into one side of the wheel disc. The single-disc wheel offers the following advantages:

Advantages of single-disc wheels over double-disc wheels:

- ➔ • Very **rapid assembly** without any special tools
- ➔ • **Less wear parts** due to 6 instead of 8 or more throwing blades, no spacer bolts, and no second disc element
- ➔ • **High performance**
 - due to high abrasive throughput
 - due to reduced vortexing of the blasting compound
 - due to reduced vortexing of the blasting compound
- ➔ • **Design improvements** optimising the flow within the turbine.

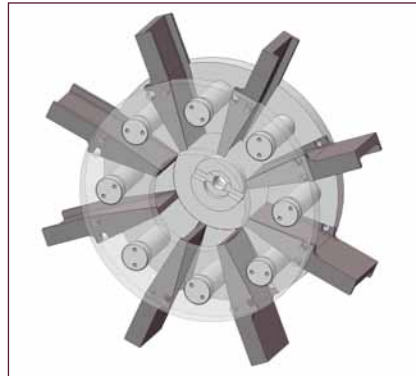

Double-disc blasting wheel with 8 throwing blades and bolts.

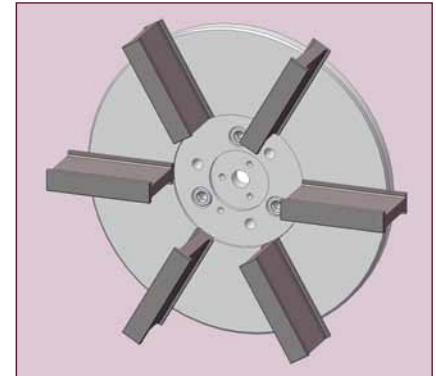

The AGTOS single-disc blasting wheel with 6 throwing blades.

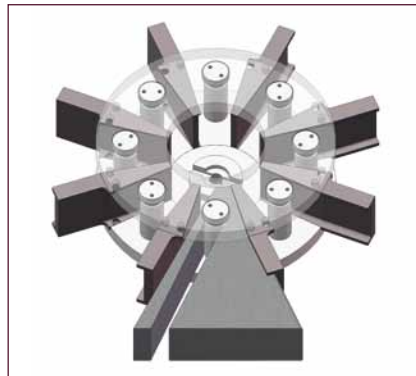

Bolts inside the double-disc wheel disturb the flow of the blasting medium. Vortexing causes a loss of blasting power.

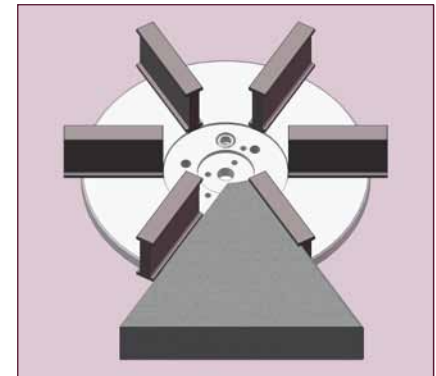

The AGTOS single-disc wheel ensures a free flow of the blasting medium. Hence, performance is vastly increased with the same power consumption.

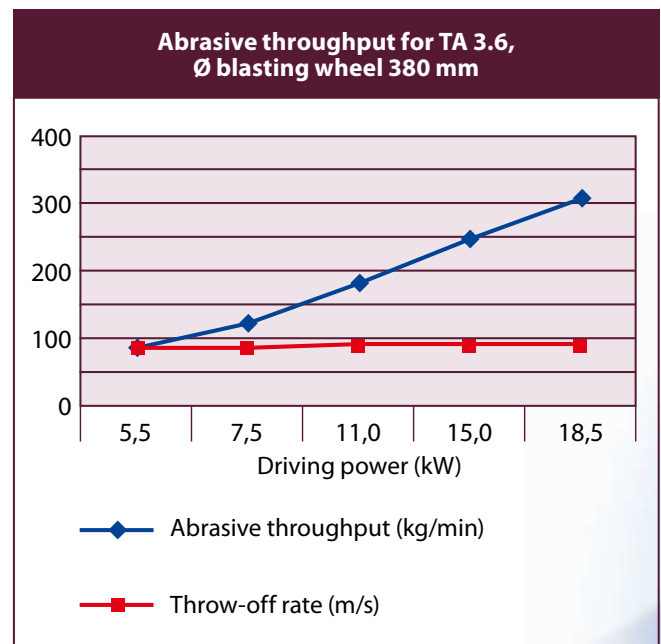
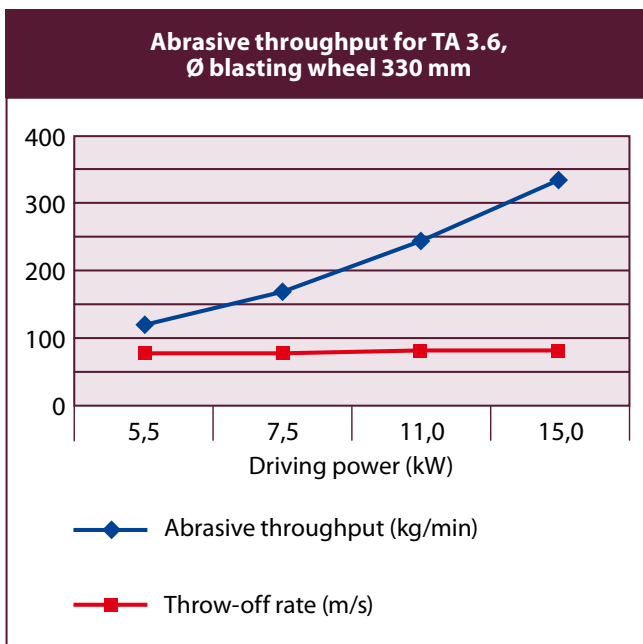

Points in Favour of AGTOS Technology



The AGTOS turbine housing

AGTOS high performance turbine housings are made of highly wear-resistant manganese steel.

The housing design is extremely maintenance friendly:

- simple design
- few screws
- throwing blades and other turbine components can be replaced from the inside and from the top

Exchangeable manganese or tool steel plates provide additional protection of the housing against wear and tear.

This means: Reduced assembly time and costs for maintenance and repair.

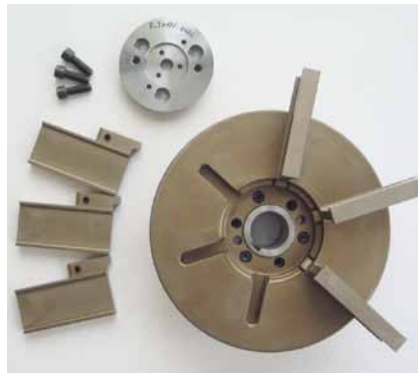
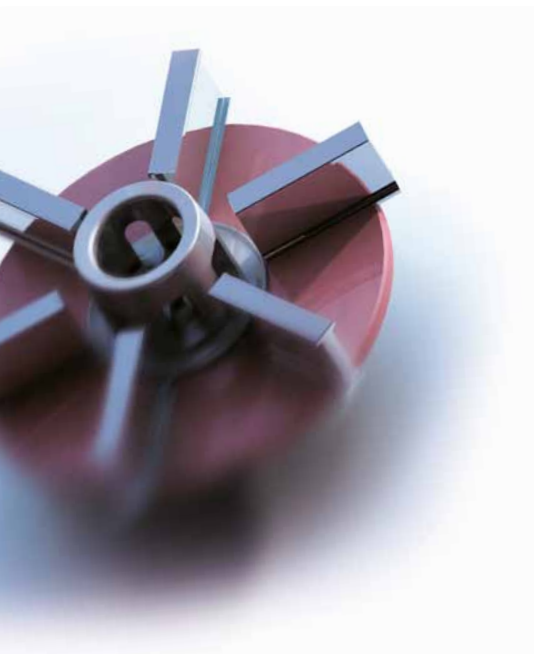

The AGTOS blasting wheel

The impeller pre-accelerates the blasting material and targets it to the throwing blades. The blasting angle can be set by means of an externally adjustable control cage. It serves to concentrate the blast directly at the Hot Spot, i.e. the area where the work-pieces are optimally exposed to the shot stream.

The throwing blades are inserted into a carrier disc and positioned and held correctly by a clamping disc.

The blasting wheel components and wear lining of the turbine housing are optionally made from tempered tool steel or cast iron, enabling the choice of the best material for all blasting applications.

The split control cage guarantees that in the case of wear only the wear plate needs replacing.

The entire throw wheel can be removed either when the housing lid is removed or through an assembly opening located at the side of the housing.



Shape of the wear lining:

For the turbine housing made of manganese high-carbon steel, the cover of the wear lining is shaped round to adjust to the flow of the blasting abrasives.



For production reasons, the flow-optimised shape of the tool steel lining is achieved with additional square parts.

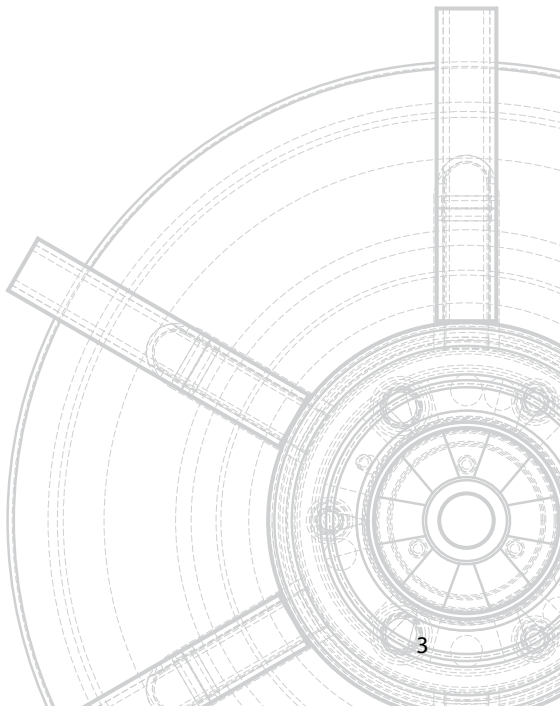

Professionalism Down to the Last Detail

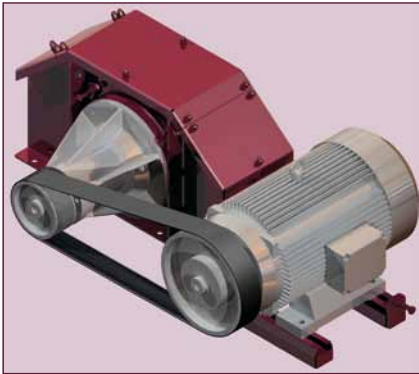

Drive

AGOS high performance turbines are driven by reliable flange motors. This applies to turbines with an engine power of 5.5, 7.5, 11, 15, 18.5, 22, and 37 kW. For higher powered systems, motors with bearing blocks can be used.



Blasting abrasives

As applications demand, **AGOS** turbines are operated with steel shot up to the size of 3 mm, making it possible to run large-size shotblasting plants even with major distances to the workpieces.

High efficiency

With their ideal flow characteristics, **AGOS** high performance turbines guarantee a high throughput rate and provide excellent blasting performance. The Hot Spot is wide and homogeneous, producing outstanding blasting results.



*Rotatable **AGOS** high performance turbine in a satellite turntable shot blasting machine.*

Custom-made turbines

For special applications (e.g. shot peening) **AGOS** high performance turbines are also designed as rotatable turbines.

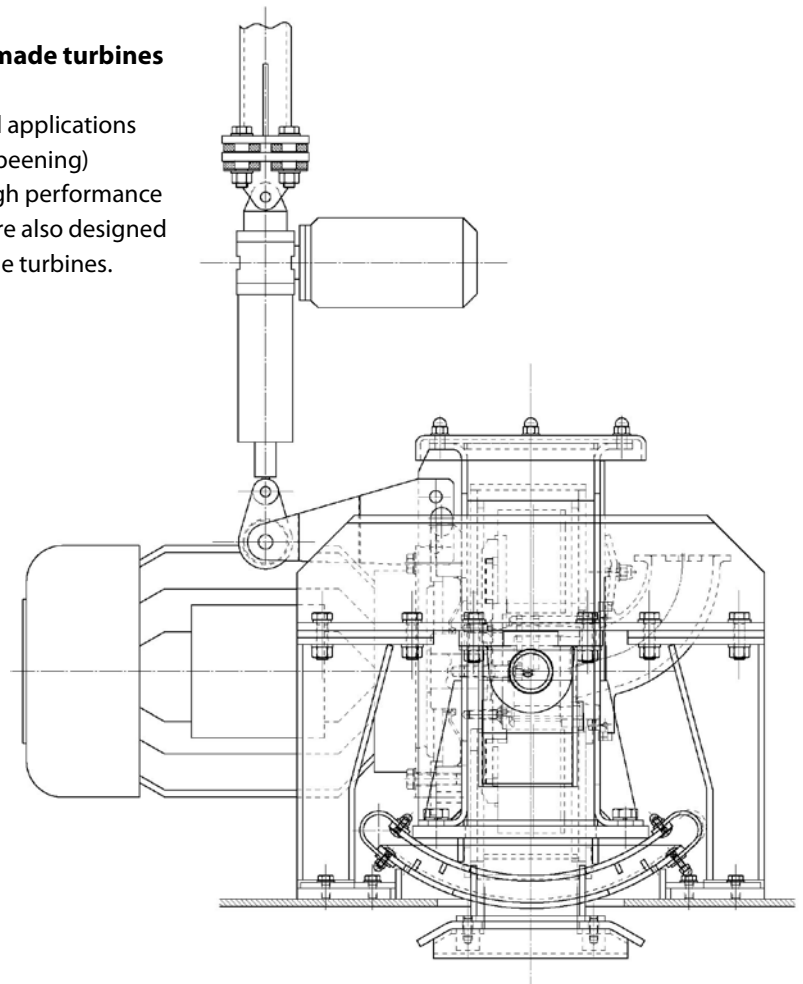

Improved Performance by New Turbine Technology



AGTOS high performance turbines are often used to improve the performance of older blasting machines; here: a monorail shot blasting machine.

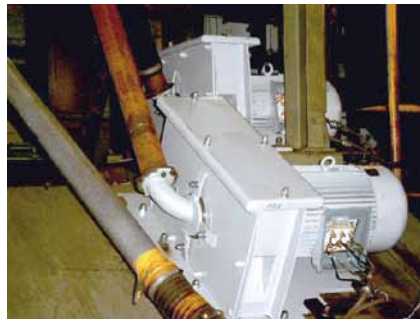

AGTOS high performance turbine in a roller conveyor shot blasting machine (top) and tumble shot blasting machine (bottom).

AGTOS high performance turbines are not exclusively installed on new equipment. All machines retrofitted with the **AGTOS** system have since achieved a higher blasting efficiency.



*Assembly of an **AGTOS** high performance turbine.*

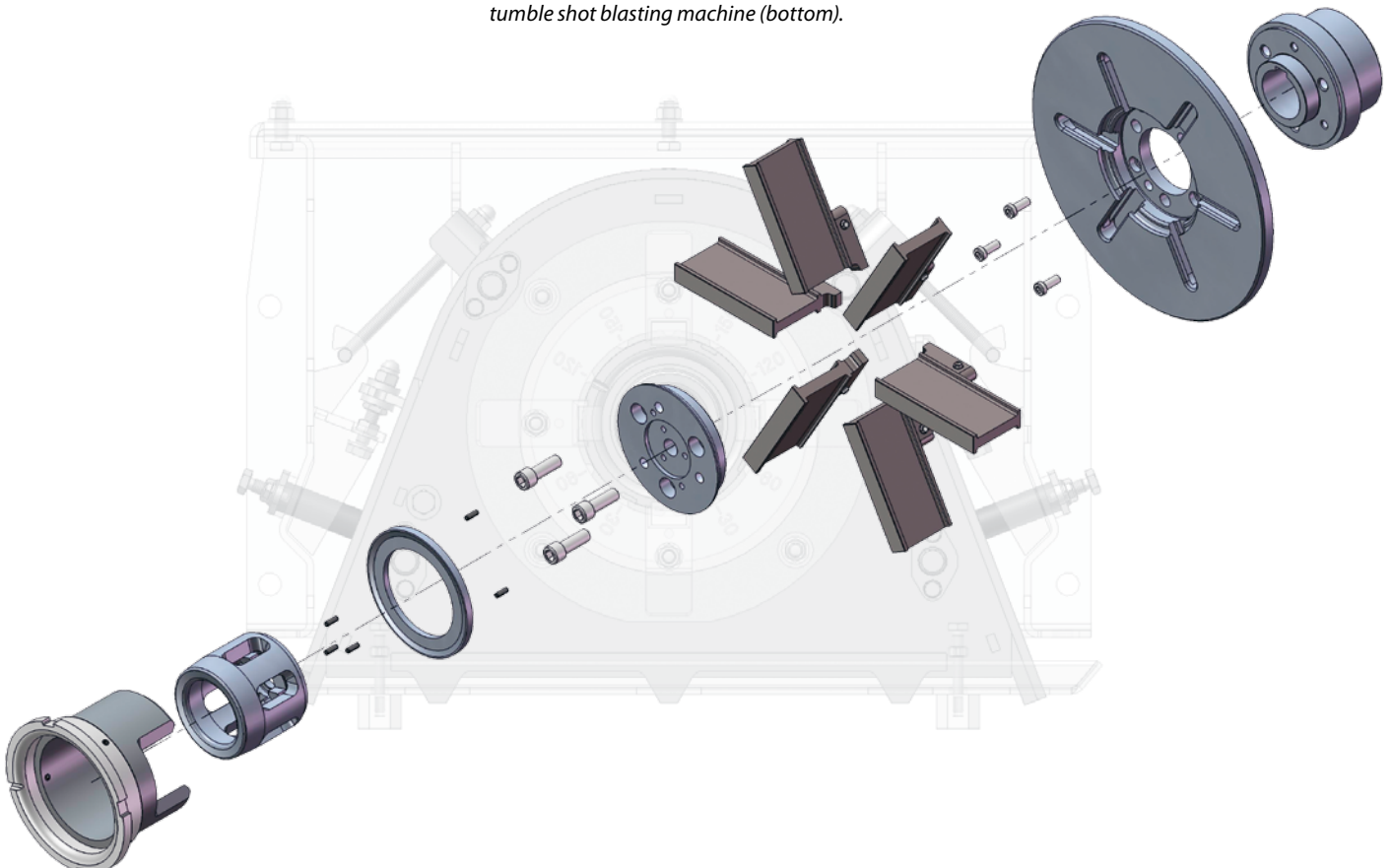

AGTOS Inside

Apart from replacing your complete turbine, we also offer our **AGTOS Inside** conversion kit. The inner workings of an **AGTOS** turbine are installed into an existing, intact turbine housing. There is a choice between two alternatives:

Alternative 1:

Blasting wheel, throwing blades, control cage, impeller, boss, and feed tube are replaced. Any existing wear linings within the turbine may be used up.

Alternative 2:

In addition to Alternative 1, the cover and side linings are also replaced, thereby reducing the investment cost while the blasting results are enhanced.

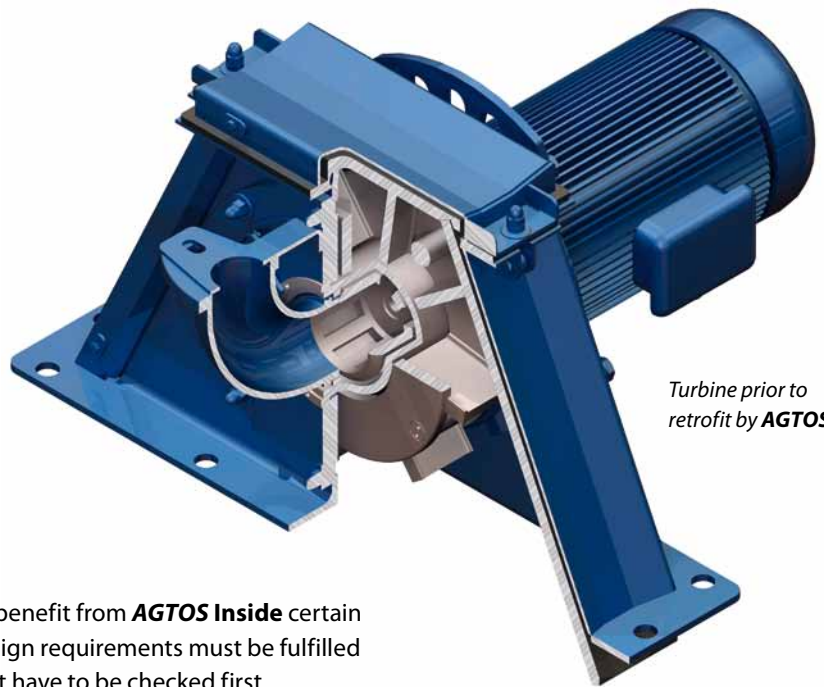

Turbine prior to retrofit by AGTOS.

To benefit from **AGTOS Inside** certain design requirements must be fulfilled that have to be checked first. **Please contact us for further information.**

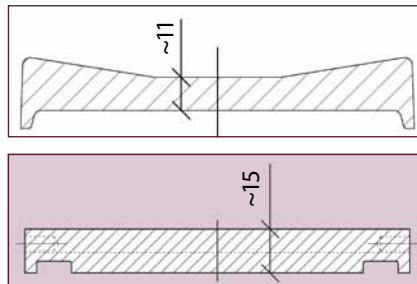

Advantages of the AGTOS wear lining over other turbine linings:

- full material thickness in the surface area of blasting
- longer lining life

Turbine with AGTOS Inside:

New feed tube

AGTOS blasting wheel without distance bolts, with six throwing blades.
Benefit: Increased abrasive throughput with the same power consumption.

Option: New wear lining of covers and broad sides.
Benefit: Improved lining life due to stronger material

Special attachment of side lining

Extended wear lining protects the machine housing

Adjacent Units

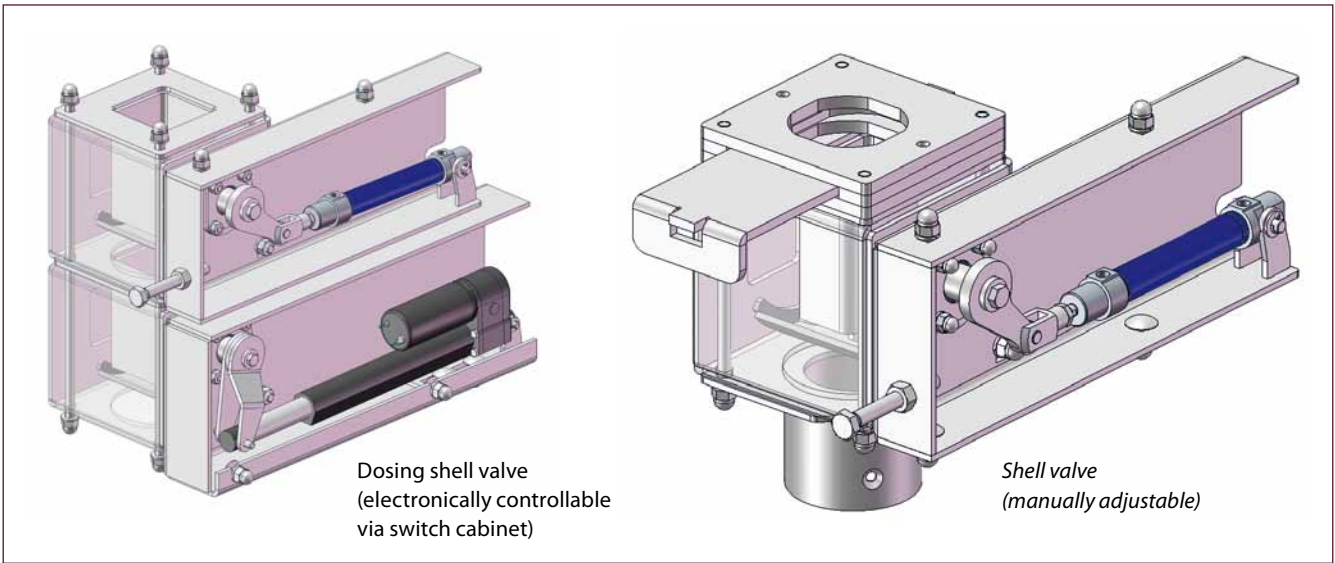

Dosing shell valve
(electronically controllable
via switch cabinet)

Shell valve
(manually adjustable)

Shell valves or magnetic valves (Magna valves) feed the blasting media to the turbines.
AGTOS shell valves are frequently used in all established shot blasting machines. They are very reliable and can be retrofitted to foreign turbines. The flow of abrasive media is controlled manually with set screws. Dosing shell valves constitute a further development in flow control. They can be adjusted electronically via switch cabinet.

Magnetic valves are used when a very precise dosage of the quantity of blasting material fed to the turbines is called for. An exact flow rate setting facilitates the accurate reproduction of a blasting process.

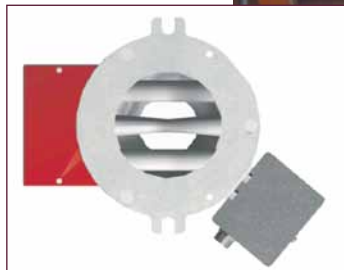

Magnetic fields control the abrasive flow rate (Magna Valve).

Turbines with a frequency control can be beneficial for certain shotblasting applications, e.g. shot peening. Frequency control allows for the continuous variation of the rotational speed of the turbine engine.

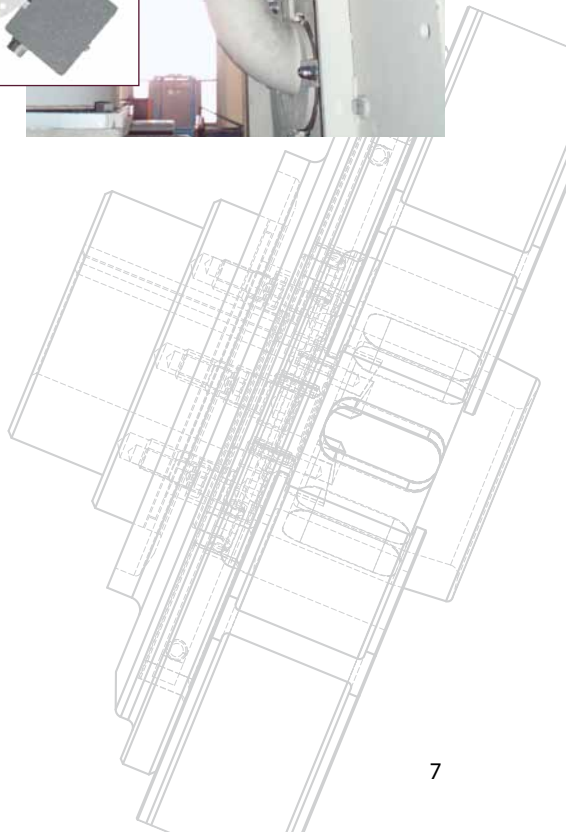

Application of AGTOS Turbines

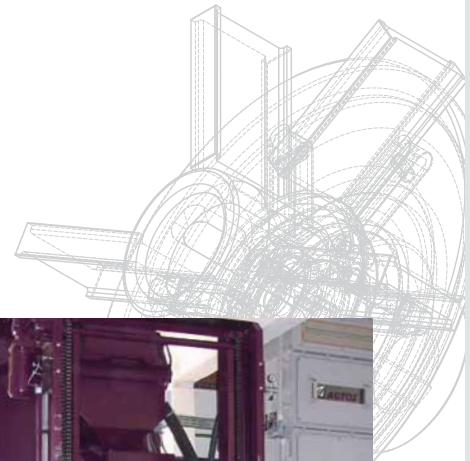

AGTOS high performance turbines installed in a continuous monorail shot blasting machine.



AGTOS high performance turbines installed in a roller conveyor shot blasting machine.



AGTOS high performance turbine installed in a tumble shot blasting machine.

AGTOS high performance turbines:

Specification	Type TA 3.6					Type TA 4.6		
Driving power (kW)	5,5	7,5	11	15	18,5	22	30	37
Nominal speed (rpm)	2860	2860	2910	2920	2920	2920	2920	2920
Direct drive (design)	B5	B5	B5	B5	B5	B5	B5	B5
Blasting wheel Ø mm	330/380	330/380	330/380	330/380	330/380	420/440/460	420/440/460	420/440/460
No. of blades	6	6	6	6	6	6	6	6
Blade width (mm)	55	55	55	55	55	75	75	75
Housing material	manganese steel					manganese steel		
Lining material	manganese steel or tempered tool steel					Manganese steel, tempered tool steel, or cast iron		
Impeller material	tempered tool steel					tempered tool steel		
Control cage material	tempered tool steel					tempered tool steel		
Feed tube material	steel casting					steel casting		
Throwing blade material	tempered tool steel or cast iron					tempered tool steel or cast iron		

For an engine power of more than 37 kW, turbines with a separate motor (V-belt drive) are used.



AGTOS

Gesellschaft für technische
Oberflächensysteme mbH

Gutenbergstraße 14
D-48282 Emsdetten

Tel.: +49(0)2572 96026-0

Fax: +49(0)2572 96026-111

info@agtos.de

www.agtos.com